



---

Installation guide  
Quadra Sparkling  
Quadra Sparkling Plus  
Tap option XL



# Installation requirements. XL

## —Components for Billi Quadra Sparkling

Before commencing installation, ensure you have identified the following.

1. Boiling water module
2. Chilled water module
3. Sparkling control box
4. CO2 regulator and cylinder
5. Dispenser upper with tubing
6. Dispenser base & mount
7. Barb locking bush
8. 4mm chrome screw & allen key
9. Large washer
10. Tube spring clamps x 3
11. 90° John Guest elbow
12. White 1/4" tube x 3
13. 600mm flexible braided hose
14. Filter cartridge (installed)
15. User guide
16. Warranty registration card
17. Warning label

## —Determine Unit Location

Plan the installation. Dispenser tube lengths, position of power and water outlets, required air space around the underbench modules and access for service must be considered before cutting tube lengths refer to Diagrams 1, 3a and 3b for clearances around units. Refer to Diagrams 4a and 4b for suggested layouts.

## —Water Supply

The Quadra Sparkling must only be connected to a cold water supply. A 1/2" BSP stop tap (not supplied) is to be installed in an easily accessible position within 600mm from the boiling water module water supply inlet.

Dynamic water supply pressure:

Min. 250 kPa, max. 1000 kPa.

Minimum water supply: 6 l/m at 250 kPa

Supply temp: min. 5°C, max. 30°C.

**Do not install with water that is microbiologically unsafe or with water of unknown quality without adequate disinfection before or after the system. Systems certified for cyst reduction may be used on disinfected water that may contain filterable cysts.**

## —Power Requirements

Two 3 pin 10 amp GPOs are required. A dedicated circuit should be provided and must be fitted with an earth leakage protection device (RCD). An externally fitted RCD device is acceptable.

Both Quadra Sparkling modules are supplied with a 1 metre flex cord and plug.

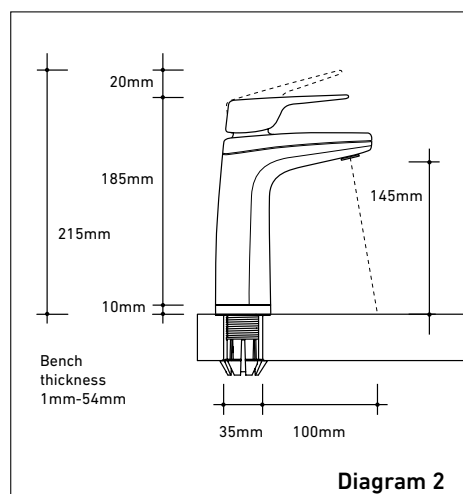
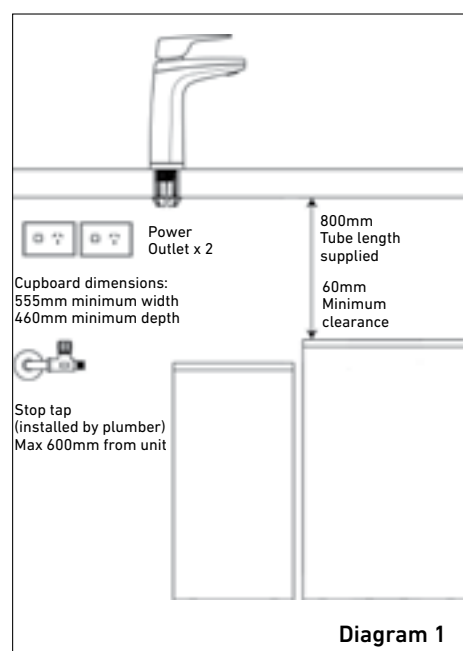

# Installation requirements. XL

Chilled Water Module Dimensions

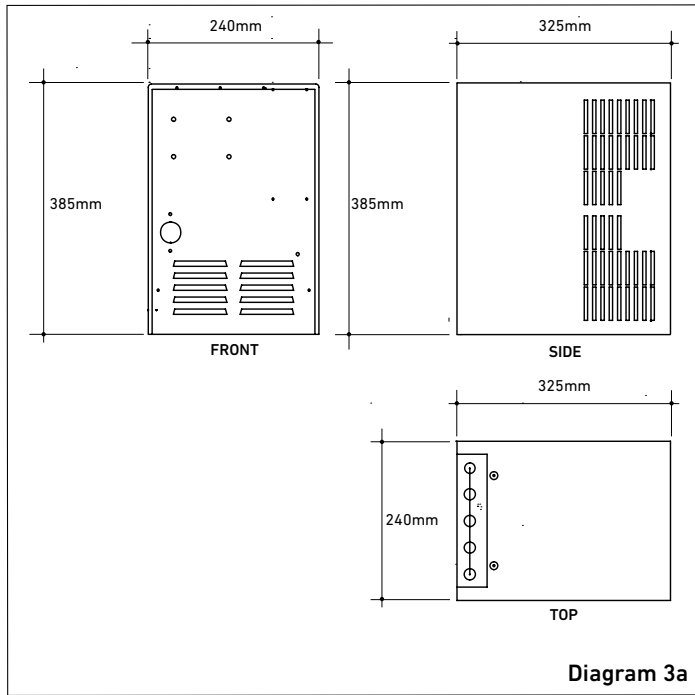

Boiling Water Module Dimensions

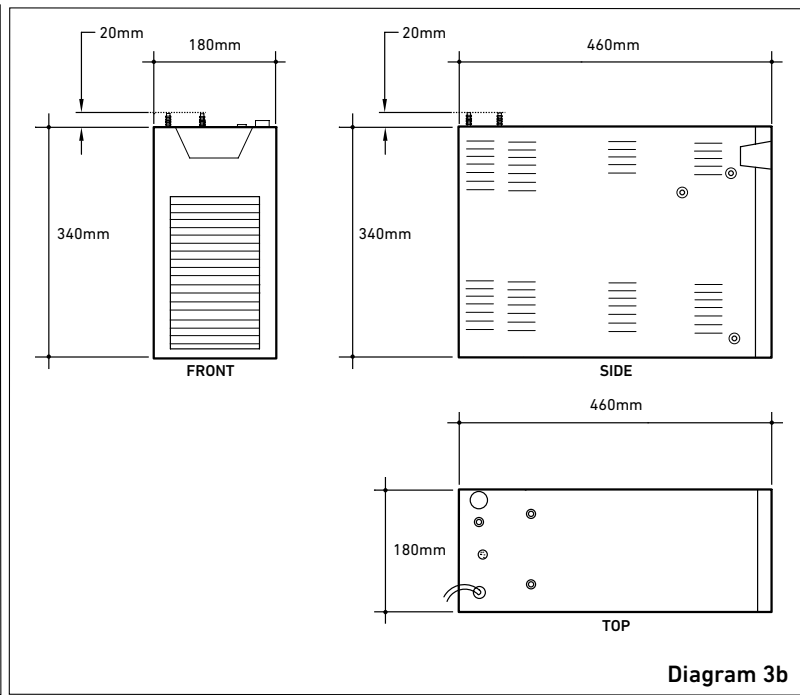

Quadra Sparkling Suggested Layout A (Plan)

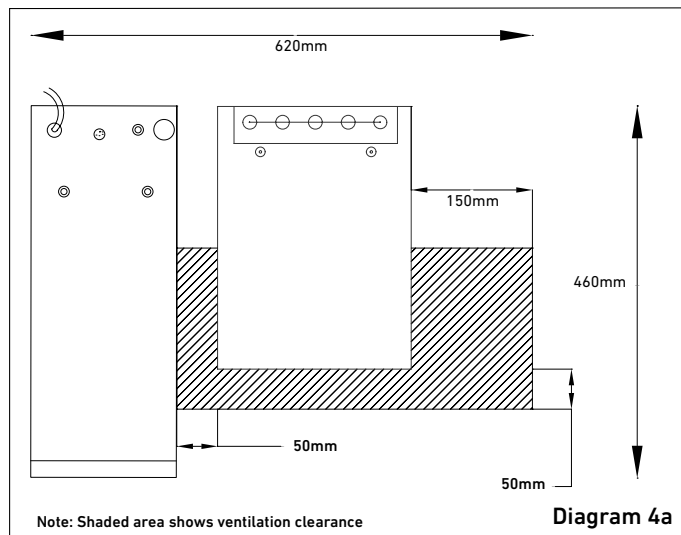

Quadra Sparkling Suggested Layout B (Plan)

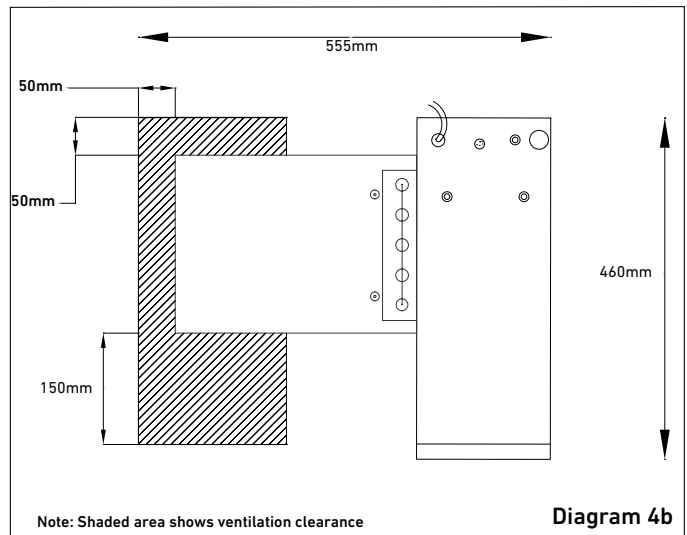

# Installing the dispenser. XL.

**IMPORTANT:** This Billi appliance is to be installed by a licensed tradesperson in accordance with AS 3500.4 or AS/NZ 3500.4.2 and in compliance with applicable state regulatory requirements. For correct operation of this appliance, it is essential to observe the manufacturer's instructions.

## 1. Install Dispenser Assembly

Determine position of dispenser mounting hole in sinktop or benchtop. Dispenser base template (Diagram 5) may be cut out and used to assist in correct positioning. Refer to Diagram 2 for clearances allowed. Hole size required is  $\varnothing 35\text{mm}$ .

### —Stainless Steel Sinktop

A suitable 35mm hole punch (Part no: 857901) is available as an accessory from Billi Pty Ltd. If possible, cut hole with die mounted below the sinktop surface so that burr is pulled downwards. Alternatively, remove burr and radius edge of hole with fine file. This allows barbed dispenser mount to slide smoothly into mounting hole.

### —Timber/Laminate Benchtop

Maximum benchtop thickness is 54mm. Cut 35mm hole in appropriate position\*. When drilling through a particle board bench top, take care to avoid a large chip breaking away as drill breaks through underside surface. We recommend drilling a small pilot hole through benchtop, partially drilling the 35mm hole from underneath and then completing drilling the hole from above. The large 30mm washer supplied may be used to secure barb where underside particle board bench top has chipped away.

\* For granite or marble benchtops we recommend you use a certified stone mason to pre-drill the hole.

## 2. Activate Dispenser Swivel Feature

To activate the swivel feature of your dispenser, you will need to remove the locking piece from the dispenser base. Push out the piece as shown in Diagram 6. This will allow the tap to move 45° to the left and right.

## 3. Fit Dispenser Base

- Cut a 35mm hole in sinktop or benchtop. Remove burr if protruding upwards.
- Push barbed mounting shaft through mount hole.
- Insert barb locking bush as shown in Diagram 7. Finger tighten nut.
- Ensure barb is centred in mount hole before tightening. Check position of base ring and gasket.
- Moderately tighten locking nut using multigrips or spanner. Take care to avoid overtightening nut which may break the plastic threaded shaft.
- Place large D washer over thread as shown in Diagram 8.
- Cut off excess threaded shaft with a hacksaw, using washer as a cutting guide.

**IMPORTANT:** Remove burrs and check internal bore is completely smooth.

## 4. Fit Dispenser Head Assembly

- Feed dispenser tubing and loom through centre hole in the following order:
  - Dispenser power cord.
  - Silicone tubes.
- Gently pull hoses from under the bench top, do not attempt to force tubing through with a pointed object as silicone tube is easily punctured. Check tubing is not kinked or twisted.
- Turn dispenser head assembly to approximately 60° from the straight ahead position of dispenser base. Slide head assembly onto base assembly whilst gently pulling tubing downwards from underneath to prevent tubing bunching and kinking. Mounting lugs will pass nut and slide down the 3 grooves on the swivel bearing.
- Once fully down, turn dispenser to straight ahead position. Fit chrome plated M4 retaining screw to lower rear threaded hole and tighten using the allen key supplied. If swivel feature activated check dispenser now swivels smoothly 45° in each direction.

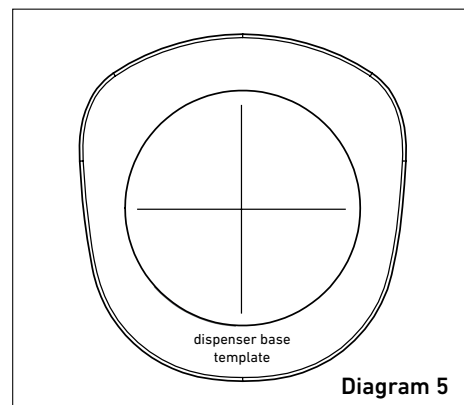

Diagram 5

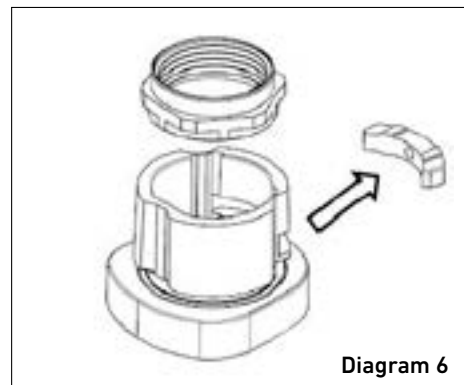

Diagram 6

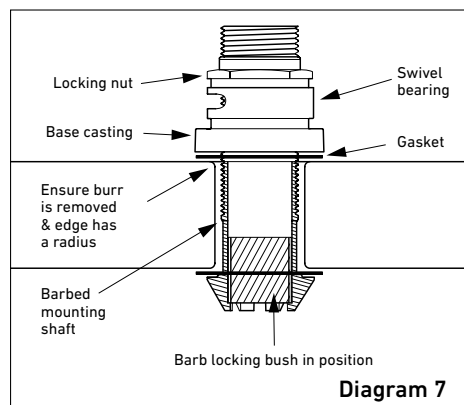

Diagram 7

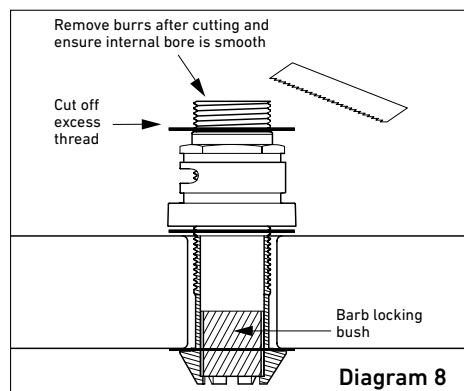

Diagram 8

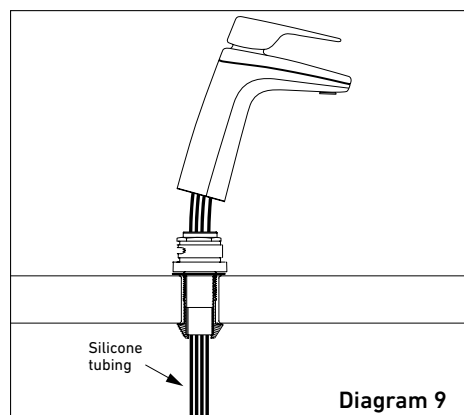

Diagram 9

# Installing underbench modules.

## 1. Flush Water Supply

Flush water supply pipework before installing the underbench unit by connecting 600mm flexible braided hose to the supply tap and running water into a bucket. Blockages/unit malfunction caused by debris are not covered under warranty.

## 2. Install Underbench Units

Take care to observe minimum clearances. Ensure there is adequate access to service the units, taking into account the tube lengths and space available Refer Diagram 1, page 2.

## 3. Connect Components

**IMPORTANT: Boiling outlet (red), vent tube (grey) tube must not be kinked and must be installed with a continual fall and no sag.**

Connect all tubing and electrical plug as shown in Diagrams 10 and 11.

Trim silicon tubes to correct lengths using a sharp knife or plastic tube cutter. Avoid leaving excess tubing which will sag, trapping water. Fit supplied spring clamps to retain silicone rubber tubing to barbed fittings. Some tube connections are made using push-fit connectors and should be trimmed to correct lengths. Tubes should be cleanly cut square using a sharp knife or plastic tube cutter. Ensure that tube ends are round and not flattened or kinked, then push into connectors firmly until properly seated (to release, press the outer ring in while pulling gently on the tube). Minimising the tube lengths will improve the performance of the chilled and sparkling water.

### —Boiling Water Module to Chilled Water Module

- Connect one end of white hose provided to the Boiling Water Module fitting labeled "AMBIENT".
- Connect the other end of the white hose to the Chilled Water Module fitting labelled "WATER SUPPLY INLET".

### —Chilled Water Module to Sparkling Control Box

- Connect blue tube to Chilled Water Module fitting labelled "CHILLED WATER OUT"
- Connect other end of blue tube to Sparkling Control Box fitting labelled "CHILLED WATER IN"
- Connect white tube to Chilled Water Module fitting labelled "SODA WATER OUT"
- Connect other end of white tube to Sparkling Control Box fitting labelled "SODA WATER IN"

### —Sparkling Control Box to Boiling Water Module

- Connect electrical lead from Sparkling Control box to Boiling Water Module socket labelled "DISPENSER POWER CORD"

### —Dispenser to Boiling Water Module

- Push red silicon tube onto barb on Boiling Water Module labelled "BOILING (RED)" and secure with spring clamp.
- Push grey silicon tube onto barb on Boiling Water Module labelled "VENT (GREY)" and secure with spring clamp.

### —Dispenser to Sparkling Control Box

- Connect white hose from the dispenser to the remaining empty fitting on the Sparkling Control Box.
- Connect electrical lead from the dispenser to the Sparkling Control Box electrical socket.

### —CO2 Cylinder to Chilled Water Module

- Push the 90° John Guest elbow on to the CO2 regulator.
- Connect one end of white hose provided to the John Guest elbow.
- Connect the other end of the white hose to the Chilled Water Module fitting labelled "CO2 INLET".
- Screw CO2 cylinder into CO2 regulator. Some gas will escape during this process.

Quadra Sparkling Top View

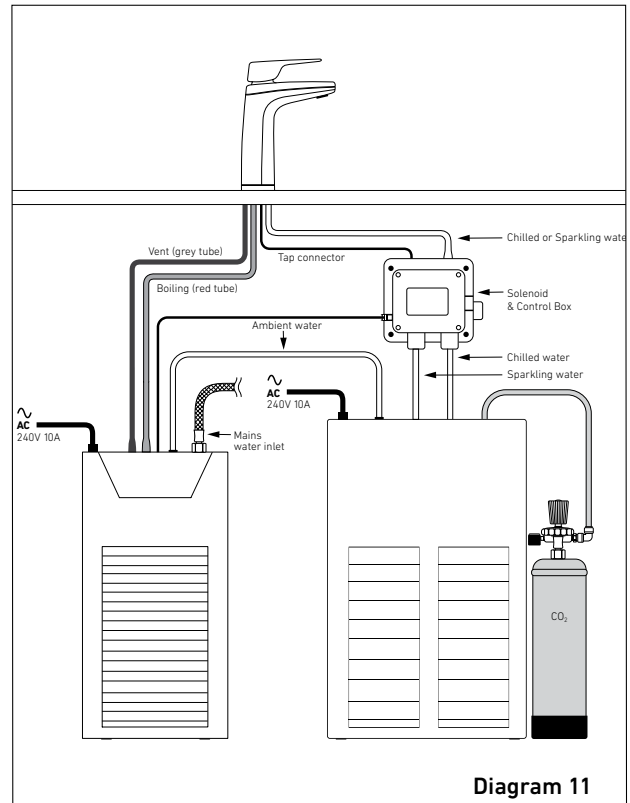
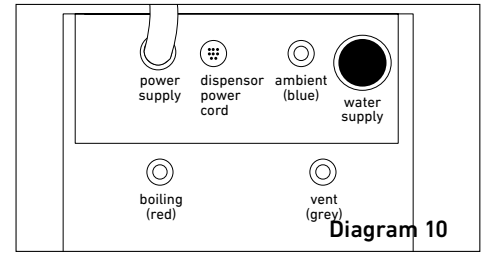

# Installing Quadra Plus mixer tap.

## —Additional Components for Billi Quadra Sparkling Plus Models

Before commencing installation, identify the following components:

1. O-ring (large)
2. Tap base ring
3. Mount clamp plate
4. Mount clamp plate gasket
5. Mount stud
6. Extended fixing nut
7. Barb adaptor fitting (short)
8. Barb adaptor fitting (extended)
9. Spring hose clamps x 2
10. ½" joining nipple
11. 1-metre PVC tubing
12. Braided flexible couplings x 3
13. Mixer Tap

## —Mixer Tap Mounting Procedure

1. Drill or punch mount hole and deburr.  
–Hole size: 35 - 38mm.  
–Sink or Benchtap thickness: 1 - 48mm.
2. Feed braided flexible couplings marked 'Water In' and 'Water Out' through mount hole leaving M10 threaded connection ends protruding upwards through hole. Fit O-ring (large) and tap base ring over tubes and sit them in place.
3. Fit barb adaptor fitting (extended) and mount stud to mixer tap body.
4. Push PVC tubing onto barb and fit spring hose clamp. Position hose clamp lugs as shown in Diagram 12.
5. Feed PVC tube down through mount hole alongside braided tubes.
6. Fit M10 threaded tubes into tap body. Match tube labels with tap base markings.
7. Feed tubing through the mount hole and place tap in correct position. Mount stud faces to front of mixer tap. Move lever from left to right to find lever centre position.
8. Fit mount clamp gasket and plate to mounting stud. Note orientation of gasket and plate – see Diagram 13.
9. Ensure tap is positioned evenly over the mount hole and that lever position is correct. Fit and tighten extended nut using a 12mm tube spanner or large flat blade screwdriver.

## —Connecting Mixer Tap to Quadra Sparkling Plus

Fit tubing connections as shown in Diagram 14 and 15.

1. Water supply inlet tube incorporates an inline strainer. Connect to ½" BSP stop tap.
2. Fit short barb adaptor to port at the rear of Quadra unit marked 'Hot Outlet'. Trim PVC tubing to correct length using sharp knife. Excess tubing will cause sagging and possible kinking. Push tube onto barb adaptor and fit spring hose clamp. Support may be needed for PVC tube if there is a horizontal run.
3. Fit braided coupling marked 'Hot Inlet' to matching port. Join to braided coupling marked 'Water Out' using ½" joining nipple.

## —Operating the Mixer Tap

Operation of the mixer tap is as with any single lever tap. Lift lever to start water flow. Swing to the left for hot water and to the right for cold water.

Hot water will not be available until boiling water tank has filled and heated.

Bubbling in the hot water flow indicates insufficient boiling water is available.

Wait a few minutes for tank to fill and heat.

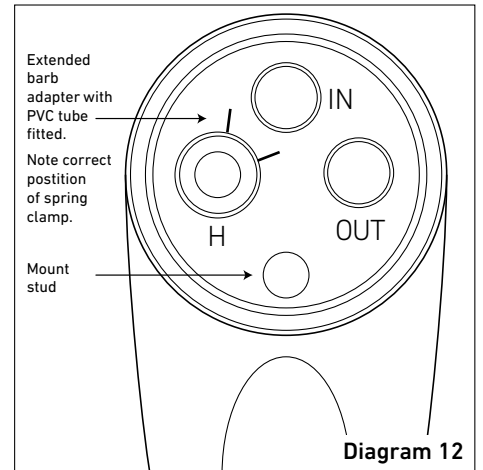

Diagram 12

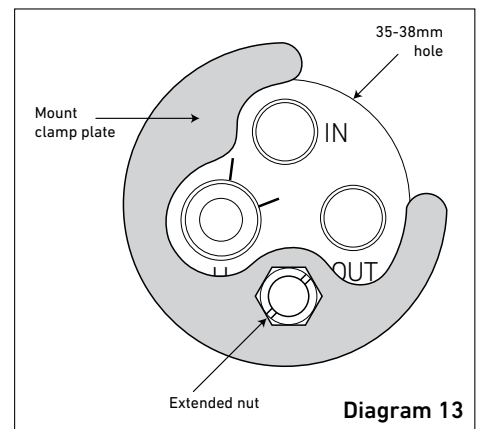

Diagram 13

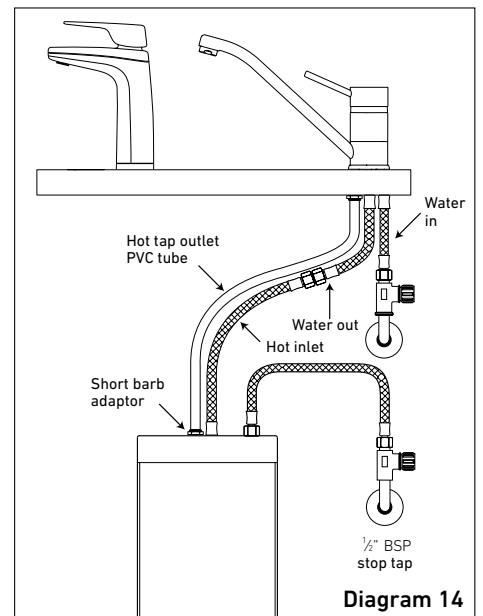

Diagram 14

## Birds Eye View

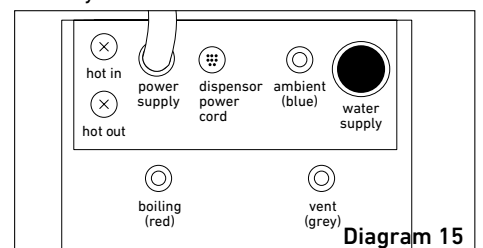

Diagram 15

# Commissioning.

---

## 1. Turn on Water Supply

Turn on water supply and ensure that there are no leaks. Remove front panel of unit and remove packing foam from under filter canister. Ensure filter canister is securely locked back into place. Replace front panel.

## 2. Connect and Turn on Electricity Supply (Boiling Water Module)

When power is applied the system checks the water level in the hot tank and if empty (below the low level sensor) then the unit will enter the boiling point calibration mode. This will normally only occur the first time a new system is turned on.

On power ON, if the hot tank level sensor is above the low level sensor, the unit will enter its normal operating mode at full power. This will happen when the system has been installed and used at least once.

**IMPORTANT: On initial power up, leave the unit for 10 minutes before attempting user setup.**

### —Boiling Point Calibration

The hot tank will first fill to the height of the low level sensor. The water is then heated until it reaches boiling point. The unit will continue to boil for up to 30 seconds while the temperature sensor calibrates.

**WARNING: Steam and small amounts of hot water may be discharged from the tap and vent during this period.**

While calibration is underway the hot water indicator (red) will double blink rapidly. The hot water set point is calibrated 0.5°C below the boiling point. Once calibrated the unit will resume normal operations and the calibration data is saved.

The unit will not re-calibrate under normal circumstances. If a repeated calibration is required the following procedure should be followed:

- turn the water supply off
- run the hot water until the hot tank is empty
- turn the power off for 5 seconds, then on again
- turn water supply on
- the unit will then re-calibrate its boiling point.

## 3. Connect and Turn on Electricity Supply (Chilled Water Module)

- Lift chilled lever on dispenser and let the water run until it stops. Check for leaks around the Sparkling Control box and fittings.
- Return the chilled lever to the centre position.
- Press both levers down together and hold for about 20 seconds. Water should run from the dispenser.
- Release the levers and check for leaks.

**Note: There may be air bubbles in the water at first as the filter is dry.**

## 4. Set Chilled Water Temperature

Set the desired water temperature using temperature control knob. Refer to Billi Quadra Sparkling User Guide.

## 5. Set Carbonation Level

- Open the CO2 regulator by turning the black knob clockwise.
- Set the initial pressure to around 2 Bar.
- Wait for the unit to come back to temperature.
- Increase the pressure to set your level of carbonation. Initial set point may vary once the unit is running, you may need to reset the pressure once the system has stabilised.

**WARNING: Do not set the pressure above 5 Bar**

## 6. Re-check Connections for Leaks

## 7. Explain Operation to User

## INSTALLATION AND COMMISSIONING CHECKLIST

- Unit is set to reflect correct tap style
- Filter packing foam removed from under filter canister.
- Dispenser mounted securely.
- Dispenser swivels 45° in each direction – M4 chrome retaining screw fitted.
- Tubing is cut to correct lengths and not kinked or sagging. Red, grey and 10mm black tubes have a continual fall.
- Tubing not twisted or kinked.
- Tubing secured correctly – nuts and spring clips.
- Water main flushed before connection to unit.
- Unit connected to COLD water supply.
- Correct air clearances around unit.
- Power circuit fitted with an RCD – earth leakage protection device.
- Sawdust cleaned out of cupboard area.
- Door vents fitted correctly (air-cooled models only).
- Unit heating and cooling (after initial fill). Red and blue dispenser icons flashing (or on continually when reached temperature).
- Boiling and chilled water flow correct.

If any difficulties arise contact **Billi Pty Ltd**: Phone 1800 812 321 (Free call). To validate your warranty refer to the warranty card or validate online at [www.billi.com.au](http://www.billi.com.au)

**For information on our filtration and services please contact The Watershop on (02) 9458 1111.**

**For continued safety of this appliance it must be installed, operated and maintained in accordance with the manufacturer's instructions.**

- Your appliance should be installed by a suitably qualified tradesperson.
- For correct operation of this appliance it is essential to observe the instructions as outlined in this booklet.
- Do not use this appliance with water that is microbiologically unsafe or with water of unknown quality without adequate disinfection before or after the system. Systems certified for cyst reduction may be used on disinfected water that may contain filterable cysts.
- Filter replacement must be performed at intervals of not more than 6 months.
- Use this appliance only as directed in these instructions and only for its designed purpose.
- This appliance is not intended for use by persons (including children) with reduced physical, sensory or mental capabilities, or lack of experience and knowledge, unless they have been given supervision or instruction concerning use of the appliance by a person responsible for their safety.
- Children should be supervised to ensure that they do not play with the appliance.
- DANGER**: The operation of the thermal cut-out indicates a possibly dangerous situation. Do not reset the thermal cut-out until the water heater has been serviced by a qualified person.
- WARNING**: Do not connect any restrictor or pressure relief device to the vent pipe of this water heater if installed.
- If the supply cord is damaged, it must be replaced by the manufacturer, its service agent or similarly qualified persons in order to avoid a hazard.
- New hose-sets supplied with the appliance are to be used and old hose-sets should not be re-used.

Designed and manufactured in Australia.

As Billi Pty Ltd has a policy of continual improvement, all details are subject to change without notice. All goods are sold subject to our published terms and conditions. Billi is a registered trademark. 0914