

Instant boiling and chilled filtered water

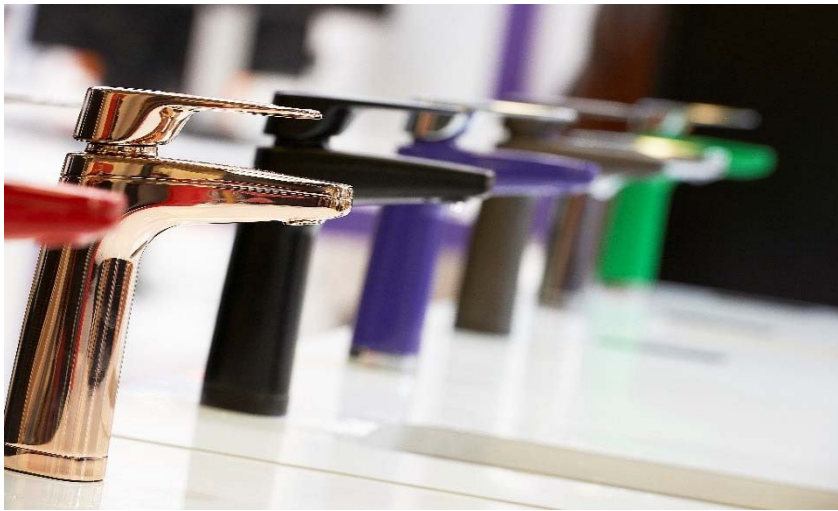

“Leading the Billi range the elegant Quadra boiling and chilled drinking water systems are space, energy and time efficient”



Space Efficient

With a focus on space saving, Billi Quadras are often less than half the size of comparable products, allowing you to make the most of the available under counter area while offering the largest capacities in the market.

Time Efficient

With the highest immediate cup rates on the market, the need to queue for hot or chilled drinking is removed with the Billi Quadra.

Energy Efficient

Billi's unique energy reclaim systems recover waste heat energy generated by chilled water and reuses the energy to preheat the boiling water, thereby saving energy. By considering composition and construction of each component in every unit, Billi achieves Australia's lowest carbon footprint. All Quadra units include a 7 day, 24 hour time switch to conserve power. Alternatively the Standby mode will also conserve power by powering down after a set period of inaction. In addition to being the most energy efficient, the Quadra's heat exchange technology ensures water usage is absolutely minimal.

Safety First

Billi's SplashFree boiling water delivery electronically varies the water flow, slowing momentarily to eliminate splashing as the water first enters the cup. All Billi dispensers are supplied standard with a safety switch.

No Cupboard Ventilation Required

The Billi Quadra water cooled units do not require ventilation grilles or a cooling fan.

Adjustable Temperatures

A simple adjustment allows the chilled water to be raised to 15°C, or lowered to 6°C for perfectly chilled, refreshing drinks, with your required temperature being quickly reached and maintained. The boiling side is set at 98.5°C.

New Unprecedented Tap Range

Four tap styles in 12 stunning and elegant colours. Popular for corporate colour matching.



Quadra Specification Sheet

Specifications and guide to model selection *

*1 cup = 170ml

Product Number	Model Name	Initial cup delivery & suggested no. of persons	Boiling water delivery cups per hour	Chilled water delivery cups per hour	Current Draw Amps	Height mm	Width mm	Depth mm
904010	Quadra Compact	20	100	150	10	340	315	365
904040	Quadra 440	40	160	150	10	340	315	465
904060	Quadra 460	60	180	175	10	340	315	465
904100	Quadra 4100	100	250	175	15	340	315	465

Power Supply

Most Quadra models require a standard 10a power supply. The Quadra 4100 model requires a 15a power outlet. All Billi models are supplied with 1m flex cord and plug.

Water Supply

A single 15mm (1/2") inline tap with a male thread should be installed in an easily accessible position. Water supply must be microbiologically safe to drink, with a minimum dynamic water pressure of 250kPa.

Filtration

Billi's premium filters ensure that health threatening pollutants and impurities such as sediment, chemicals, heavy metals, chlorine and pesticides are safely removed leaving you with refreshingly clean drinking water. All Billi cartridges are certified by global public safety agency NSF International. Filter changes are made simple by our swing change system, and replacements are obtained by calling The Watershop on (02) 9458 1111.

Warranty

All components of the Billi Quadra are covered by a 12 month warranty. This does not include filter cartridges which are consumables and therefore not covered by warranty.

Certifications

Every Billi drinking water appliance is manufactured under a certified quality control system. The Bill Quadra has been tested and complies with all required standards including: Watermark Licence Number 21525; Tested to AS3498 and AS/NZS4020; Victorian Electrical Safety Act 1998 Approval Number CS1006600V, AS/NZ ISO9002; AS1428 Accessibility Design Requirements; Section J6 of the BCA, Certificate Number QEC 11627: C-Tick approved.

Preferred installation layout

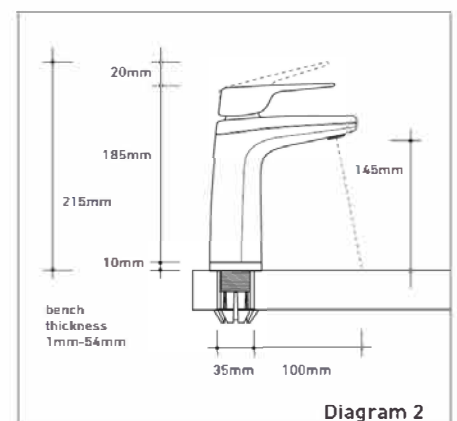
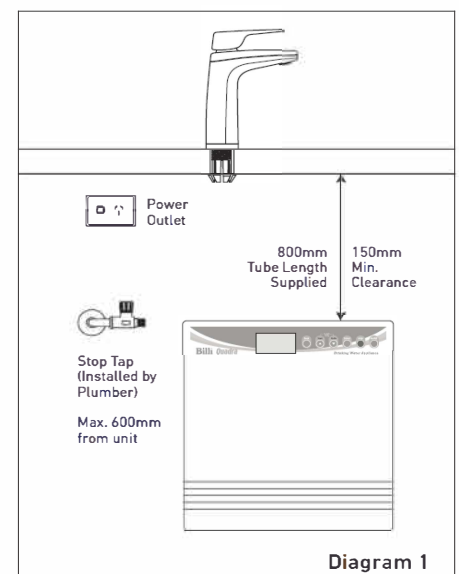

Technical Advice?

Please call us on 02 9458 1111